

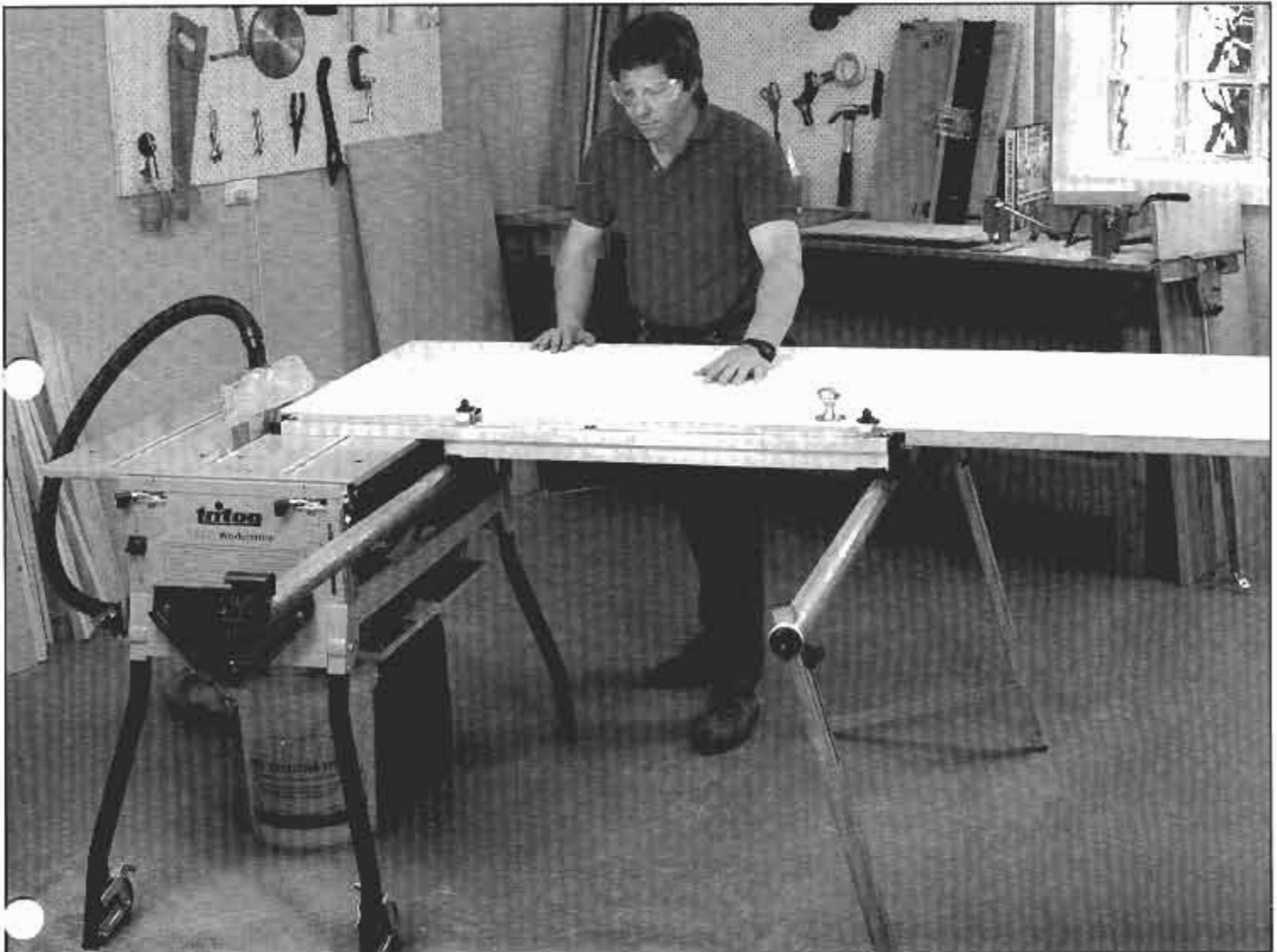

Sliding Extension Table



Assembling and Operating Instructions

Table & Fence Ass'y	Qty.	Ref.	Outer Track Assembly	Qty.	Ref.	Inner Track Assembly	Qty.	Ref.
Long Extrusion	2	(2)	Outer Track	1	(29)	Inner Track	1	(33)
Short Extrusion	2	(3)	Leg <small>PACKED INSIDE TRACKS</small>	2	(20)	Support Bracket	2	(32)
Scale	2	(10)	Foot <small>PACKED INSIDE TRACKS</small>	2	(19)	Skid Assembly	2	(36)
Brace <small>(orange)</small>	2	(8)	Leg Plate	4	(21)	Front Panel Bracket	1	(30)
Corner Bracket	4	(4)	Leg Clamp Ass'y	2	(28)	Rear Panel Bracket	1	(31)
Inner Bearing (smaller)	2	(11)	Fastener Bag 2			Fastener Bag 3 (inside Bag 2)		
Outer Bearing (larger)	2	(13)	Hex Bolt M6 x 40	6	(22)	Coach Bolt M6 x 20	2	(16)
Fence Assembly	1	(15)	Nyloc Nut M6	6	(23)	Round Knob with nut	2	(18)
Fence Clamp Ass'y	2	(14)	Screw M4 x 10	4	(26)	Coach Bolt M6 x 12	4	(34)
Fastener Bag 1			Square Nut M4	4	(27)	Washer M6	4	(6)
Brace Bracket	4	(7)	Height Stop	2	(17)	Locking Latch	2	(37)
Flange Nut M6	14	(1)	Coach Bolt M6 x 20	2	(16)	Hex Bolt M6 x 45	2	(38)
Hex Bolt M6 x 10	20	(5)	Round Knob with Nut	2	(18)	Nyloc Nut M6	6	(23)
Hex Nut M6	8	(9)	Angled Tube Closer	2	(24)	Screw M6 x 10	2	(39)
Washer M6	20	(6)	Flat Tube Closer	4	(25)	Flange Nut M6	2	(1)
Screw M6x16	4	(12)						

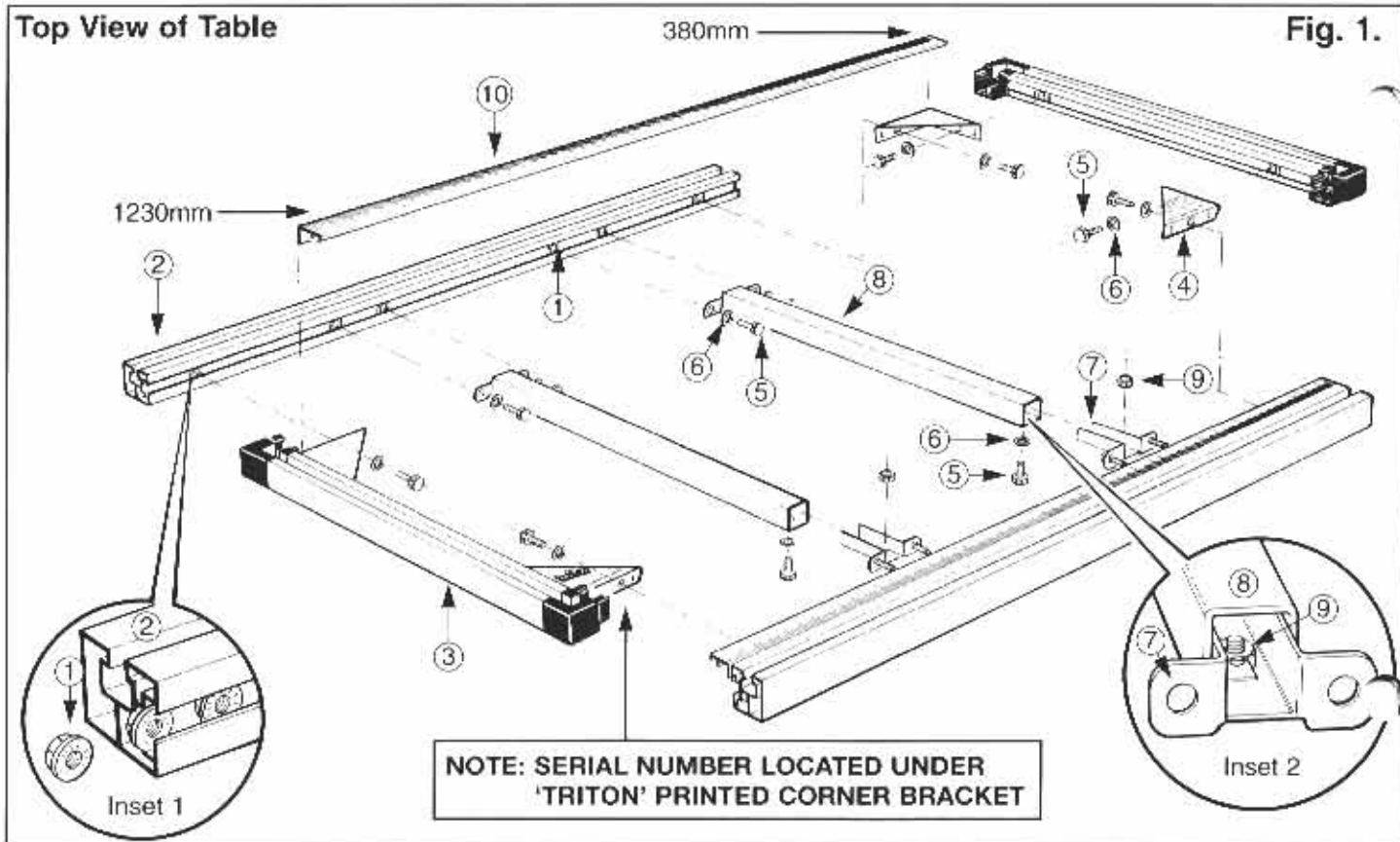

ASSEMBLING THE TABLE & RIP FENCE

STEP 1

Using the fasteners from Bag #1, insert 6 Flange Nuts (1) into each Long Extrusion (2) as shown in Inset 1, Fig. 1.

Lay out the two long extrusions and the two short extrusions as shown in Fig. 1, making sure that all of the flange nuts are facing inwards.

Plug the corner blocks of the Short Extrusions (3) into the ends of the long extrusions and tap fully home with a mallet (or similar).

STEP 2

Turn the table over (face down) on a flat surface and **loosely** attach the Corner Brackets (4), using the Hex Bolts (5) and Washers (6) into the flange nuts. (Slide the flange nuts into position using a screwdriver).

Ensure that the two printed corner brackets are bolted with their correct edges on the same long extrusion. See Fig. 1.

Loosely fit the Brace Brackets (7) to the Braces (8) using Hex Bolts (5), Washers (6) and Hex Nuts (9). See Inset 2, Fig. 1.

Position the braces about 310mm in from each side of the frame and loosely attach the braces with hex bolts and washers into the remaining flange nuts. Do not tighten any of the fasteners yet.

You should have two flange nuts left over. See Fig. 9.

Fig. 2

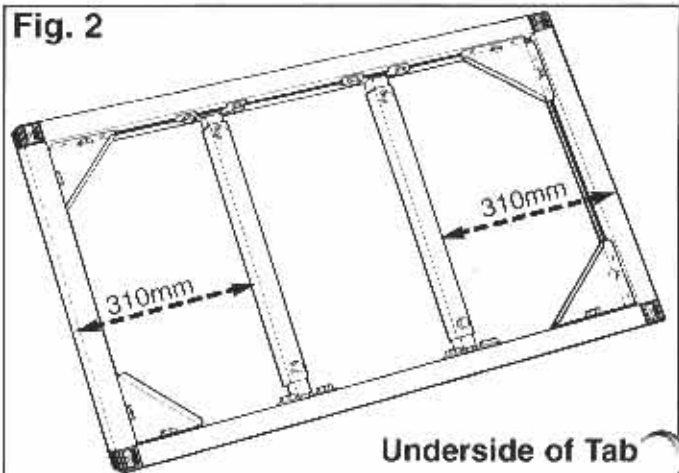

STEP 3

Turn the table face upwards again and fit the Scales (10) between the long extrusions and the loosely attached brace & corner brackets. The scales should "click" into the correct position, and should be flush with the top face of the long extrusions. Make sure the 380mm end of each scale is butted up against the short extrusion, with any slight gap at the 1230mm end.

Turn the table over again (face down). Make sure the corner brackets are pushed fully home into the corners, and that the plastic corner blocks are still fully inserted into the ends of the extrusions.

Tighten the 8 bolts holding the corner brackets. Do not over-tighten. (Tighten each pair of bolts a little at a time, to ensure you don't distort the frame).

Next tighten the 8 bolts holding the brace brackets to the long extrusions, and finally tighten the 4 bolts through the braces.

STEP 4

Plug the two smaller Inner Bearings (11) into the corner blocks below the "380mm" scale readings and tighten using the Countersunk Screws (12) and Hex Nuts (9). The two longer Outer Bearings (13) are fitted to the corner blocks near the 1230mm scale readings as in Fig. 3.

STEP 5

Take apart the Fence Clamp Assemblies (14) and reassemble them through the slot in the Fence Assembly (15) as shown in Fig. 3.

With the clamp assemblies loosened, lower the square feet into two corner blocks as shown. Slide the fence along the extrusions to position it wherever you like, and test the clamping action. If necessary, spray the inside of the fence with a spray lubricant, such as RP7 or WD40, to improve the fence sliding action.

ASSEMBLING THE OUTER TRACK

STEP 6

Insert the Coach Bolts (16) through the slots in the Legs (20), and fit the Height Stops (17) and Round Knobs (18) onto them, as shown in Fig. 4.

Attach the Feet (19) to the legs using the Leg Plates (21), Hex Bolts (22) and Nyloc Nuts (23) as shown. Note: the raised bumps on the leg plates must face inwards, touching the legs (see lower Inset Fig. 4). The feet should face away from the leg slots as shown.

Do not fully tighten the bolt which passes through each leg. The foot is designed to swing around on this bolt for easy storage.

STEP 7

Tap the Angled Tube Closers (24) into the bottoms of the legs ensuring they are correctly oriented, as shown. Tap the Flat Tube Closers (25) into the remaining tube ends.

STEP 8

Loosely fit the Philips-Head Screws (26) and Square Nuts (27) through the holes in each Clamp Assembly (28) as shown in the top inset Fig. 4. Tap the assemblies onto the ends of the Outer Track (29) clamping the screws in the notches.

Loosen the large round knobs and align the cutouts in the clamps with the square cutouts in the track.

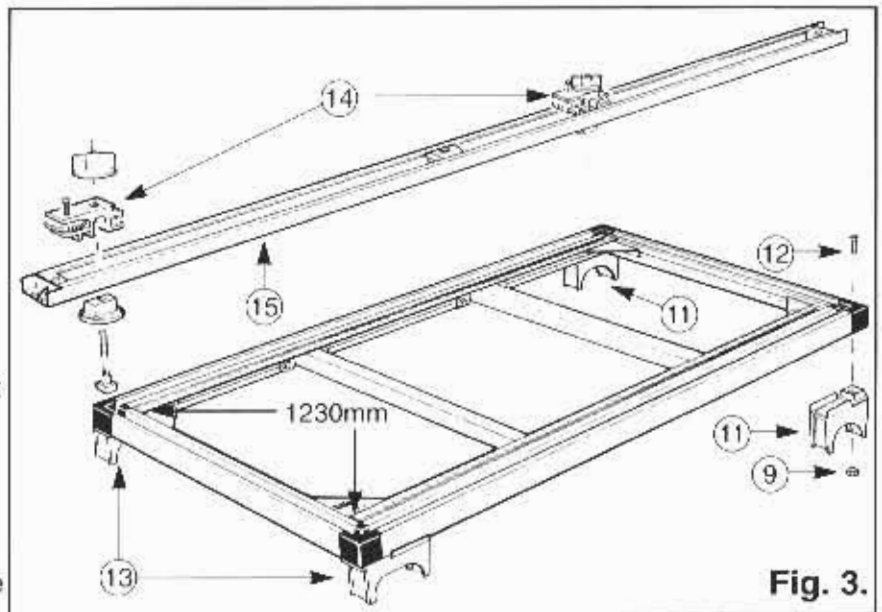

Fig. 3.

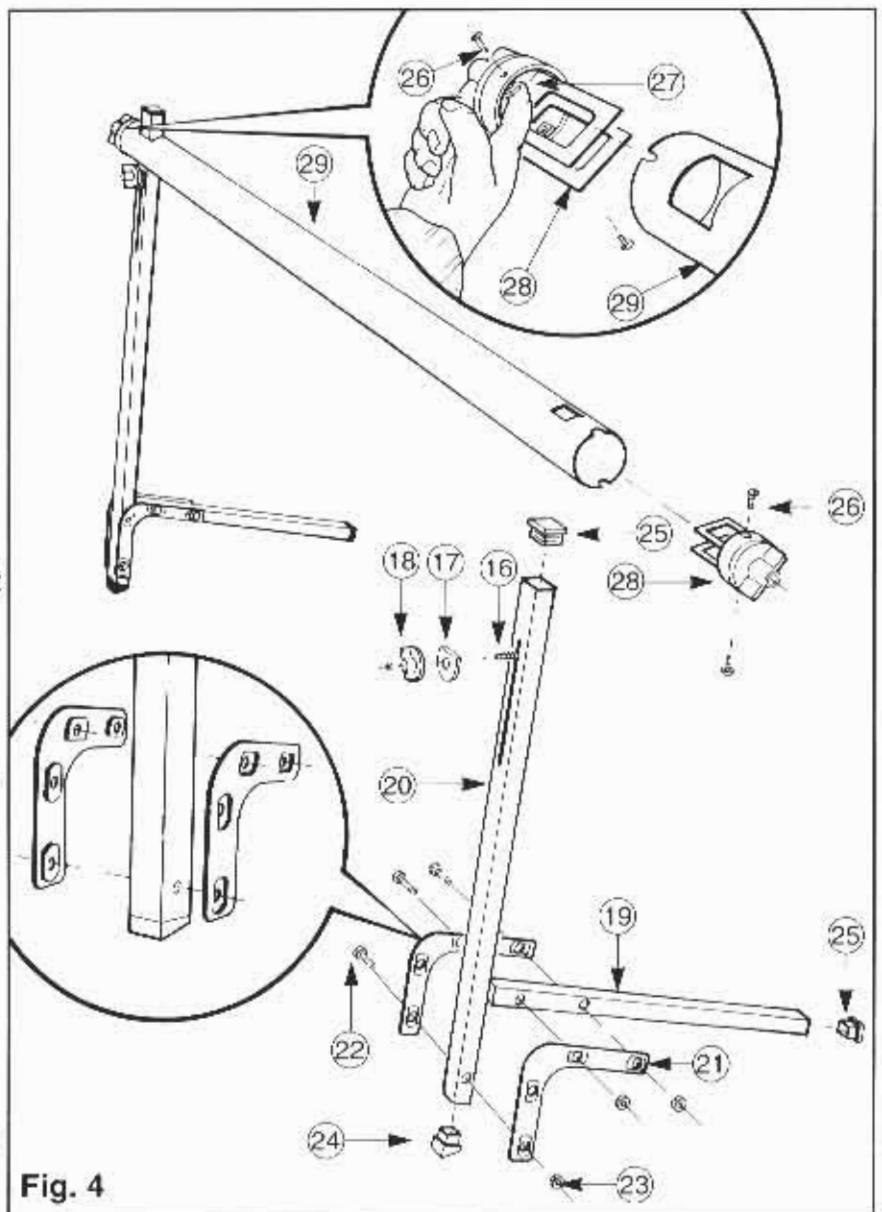

Fig. 4

Insert the legs through the track cut-outs and tighten the large round knobs to clamp. Now tighten the Philips-head screws (26). Slide the height stops up the leg slots until they touch the outer track and tighten into position. They help set the correct height for future set ups, and serve as protection against track slippage under heavy load.

FITTING THE INNER TRACK

STEP 9

Loosely bolt the Support Brackets (32) to the brackets on the Inner Track (33) using the short Coach Bolts (34), Washers (6) and Nyloc Nuts (9), as shown in Fig. 5. **Do not yet tighten.** Note the orientation of the brackets in regard to the long and short overhang of the inner track.

Loosely fasten the longer Coach Bolts (16) and Round Knobs (18) onto the support brackets as shown in Fig. 5.

Undo the large round knob (one turn only) on each Skid Assembly (36) and insert them into the ends of the inner track. With the skids pointing up as shown, firmly tighten the knobs.

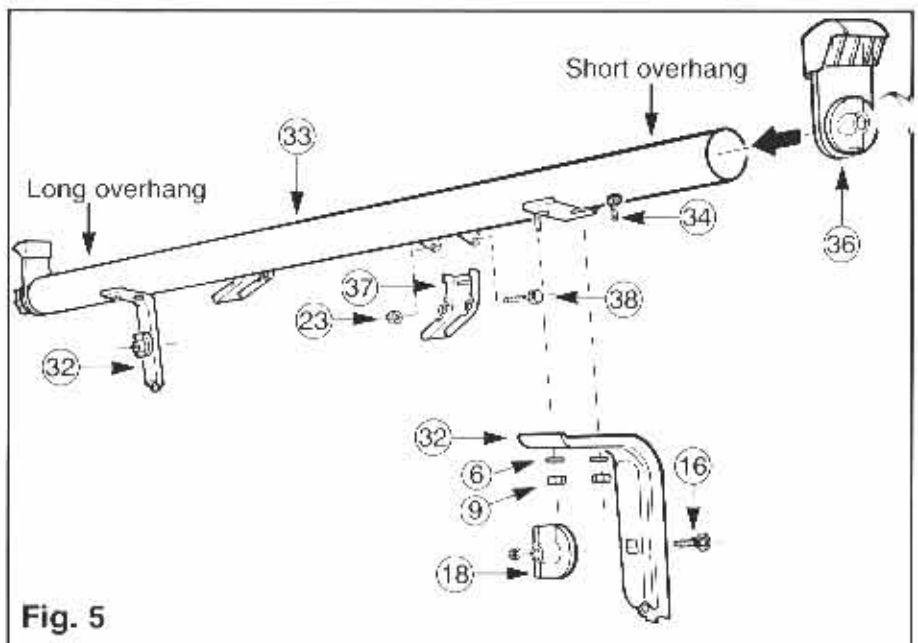

Fig. 5

STEP 10

Fasten the two Locking Latches (37) onto the latch brackets using the Hex Bolts (38) and Nyloc Nuts (23). Ensure the rectangular windows in the latches are oriented as shown in Fig. 5. Tighten the bolts until the latches pivot firmly.

STEP 11

Fit the End Panel Brackets (30) and (31) to the left-hand side of the Workcentre (when viewed from the front panel, which has the switchbox). The brackets are handed... the long edge flanges should wrap around the faces of the end panels. See Fig. 6.

At the top of each bracket, use the bolt, washer and nut which hold the left-hand bearing channel in position. At the bottom of each bracket, fit the Philips-Head Screw (39) and flange nut (1), but do not tighten yet.

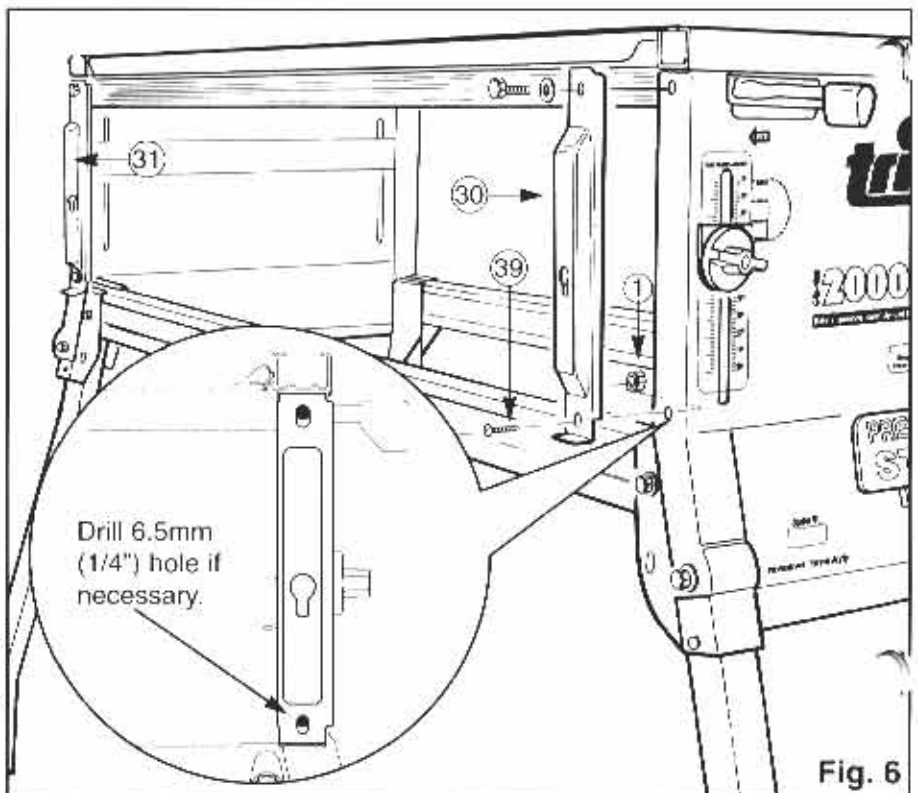

Fig. 6

Note: if you have a MK3 Workcentre or an early Series 2000 Workcentre (pre-305000 serial no.) you will have to drill the lower holes through the end panel flanges. If drilling, make sure you position the holes as shown in the inset in Fig. 6, to give you the full range of height adjustment in the bracket. Centre punch the hole positions and drill 1/4" or 6.5mm holes.

Fit the inner track to the Workcentre by locating the coach bolt heads through the keyholes in the end panel brackets. Tighten the round knobs and then temporarily tighten the four nyloc nuts (9) holding the inner track to the brackets.

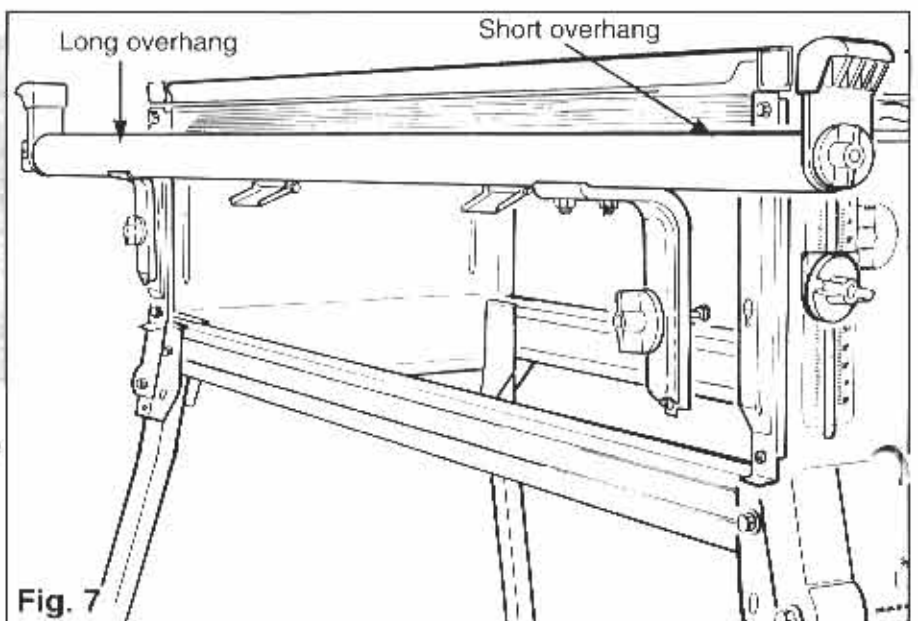

Fig. 7

ALIGNING THE TRACKS

STEP 12

On Series 2000 Workcentres, kick the legs of the Workcentre diagonally outwards to ensure that it is fully stable on the folding stand.

Position the outer track parallel to the inner track approximately 850mm away from it. Place the table onto the tracks with the inner (smaller) bearings on the inner track. **Always fit the table in this orientation.** Slide the table to each end of its travel and adjust the position of the outer track. The lengthened outer bearings make this a non-critical adjustment.

STEP 13

Next you have to fine-tune the height of the inner track. Fit the extension table fence to the sliding table so that it extends across the Workcentre table as shown in Fig. 11. Loosen the front bearing channel bolt and adjust the height of the front panel bracket until the bottom of the fence is around 0.5 - 1mm above the Workcentre table. Slide the table to the rear of the workcentre and adjust the height of the rear bracket. Tighten the bolts and Philips-head screws holding the brackets to the end panels.

STEP 14

Next, adjust the height of the outer track until the fence is level, and parallel to the Workcentre table.

Check the table throughout its travel for diagonal rocking on the tracks, and fine tune the height of the outer track if necessary. Adjust the height stops on the outer track legs to lock in the correct height.

With the sliding table positioned midway along the tracks, engage the front and rear locking latches (Fig. 7). Adjust the Philips-Head screws until the heads enter the rectangular windows and the table cannot be lifted. (You will have to unlock the latches and lift the table clear to make these adjustments).

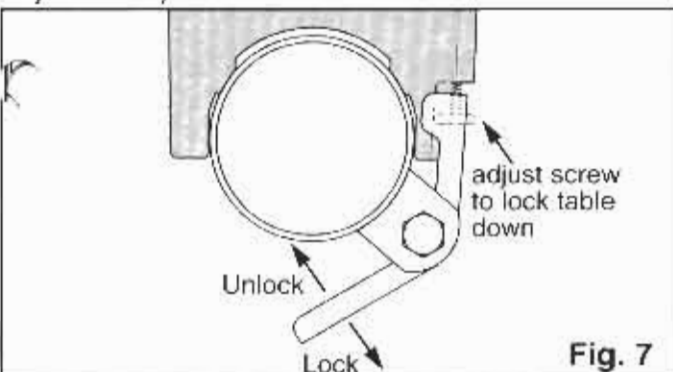

Fig. 7

STEP 15

The last step is to fine-tune the inner track position in the horizontal plane, to ensure that the extension table scales are accurate.

Series 2000 Workcentres: With the extension table fitted and locked, and the rip fence removed, insert the standard Workcentre rip fence and set it to 500mm using the end panel calibration marks. Loosen the four nyloc nuts on the inner track support brackets and adjust the inner track sideways until both front and rear scales read exactly 500mm, when sighting down the front face of the Workcentre rip fence. Tighten the four nuts and remove the Workcentre rip fence.

MK3 Workcentres: Extend the extension table fence across the Workcentre until the tip is level with the left-hand edge of the saw slot. Check for parallel by sliding the extension table so that the fence tip runs the length of the saw slot. Loosen the four nyloc nuts on the inner track support brackets and adjust the position of the track until the fence tip aligns perfectly with the saw slot at both ends of the table travel.

To ensure the correct scale reading, position the extension table with the front scale level with the front of the saw blade and measure from the blade teeth to check the scale reading. Adjust the position of the inner track if necessary until the scales are accurate, ensuring the track is moved by exactly the same amount at each end.

Finally, double check the parallel alignment and scale accuracy by repeating the above steps, or by making a test cut.

Your Sliding Extension Table is now fully assembled and ready for use.

Using the Fence Hold-Down Clamps

When cutting large or awkward pieces in any of the Sliding Table modes, you should secure your workpiece using the fence hold-down clamps.

Swing the fence clamps around until the hold-down feet overhang the workpiece. With the fence locked, lower the feet until they press firmly on the workpiece by spinning the thumb wheels clockwise. See Fig. 8.

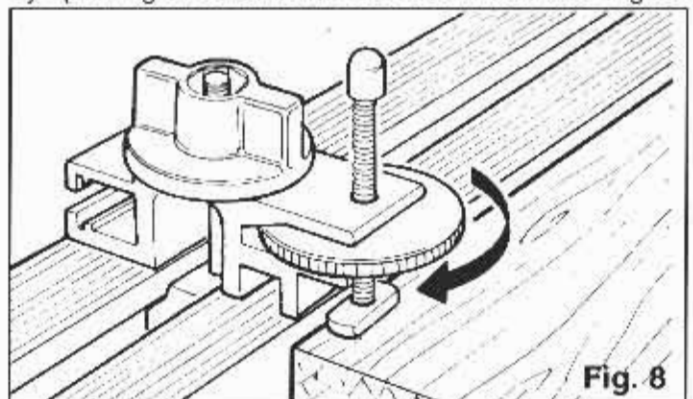

Fig. 8

Attaching Fixtures to the Fence

Two additional flange nuts have been provided in Bag No. 1 for attaching fixtures or sub-fences to the rip fence. Rotate the fence clamps so the rear is level with the front face of the rip fence. Insert the flange nuts into the slots as shown in Fig. 7 and attach your fixture using M6 bolts (not supplied).

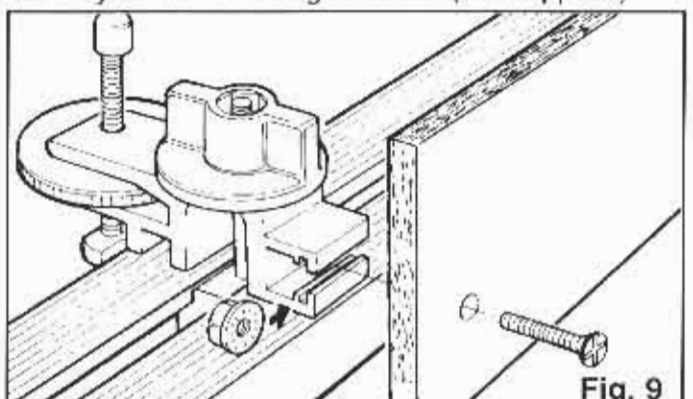
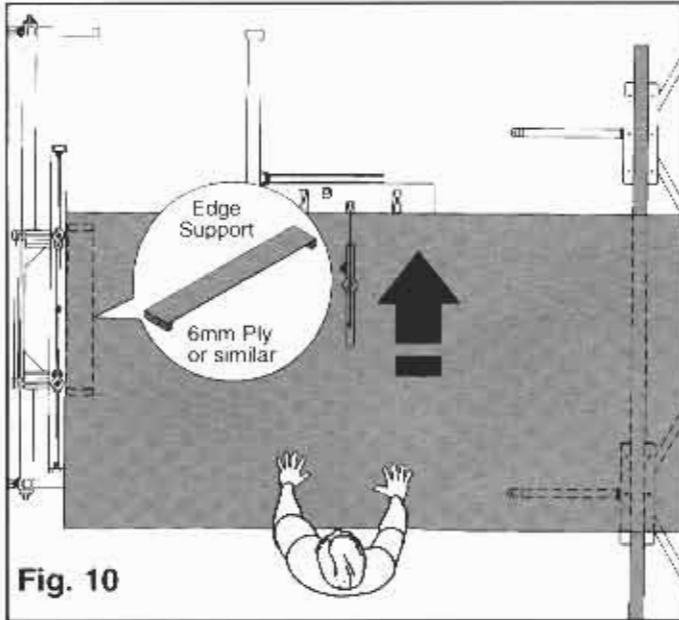

Fig. 9

OPERATING - Table Locked

Lock the table using the front and rear locking latches and fit the rip fence as shown in Fig. 10. Set your width by sighting the scales down the front face of the fence. **Ensure the fence is always set parallel to the blade.** Turn the hold-down clamps around so they don't overhang the workpiece.



Ensure that the overhead guard is lowered onto the workpiece. Press the sheet against the fence at all times. When ripping large sheets the plastic skids at the ends of the inner track will provide additional support. However when handling very large workpieces it is best to use Triton Multi-Stands (shown holding a length of wood) or have someone assist you.

When ripping thin workpieces you may need to fit an edge support (Inset - Fig. 10) against the rip fence, to prevent the corner of the workpiece from dipping into the table openings.

MK3 Workcentres: to rip in the 260mm - 380mm range, clamp a 1200mm long x 200mm wide packer to the extension table fence, using the hold-down clamps. When setting the desired width, remember to add 200mm.

NOTE: ALL SLIDING SURFACES WILL BENEFIT FROM A SPARING AMOUNT OF SPRAY LUBRICANT.

OPERATING - Table Sliding

- Always slide the extension table the full length of the tracks before making your cut. Check that the rip fence clears the saw blade, and does not hit or ride up on the Workcentre table. Check that the sliding table does not rock on its tracks. Adjust the outer track height if necessary.
- Use the fence hold-down clamps whenever possible.

Crosscutting

Position the rip fence as shown in Fig. 11. In tightening the clamps, ensure that the fence is pulled fully toward the outer edge of the table, for absolute squareness.

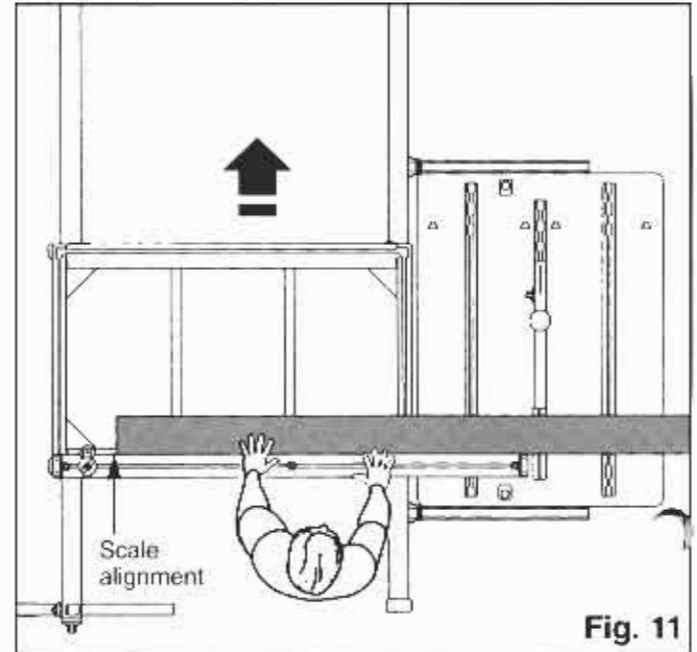

For gauging lengths up to 1240mm, you can align the end of the workpiece with the desired scale reading. For longer pieces, touch the fence tip against the saw blade teeth and use this to align a cutting mark on the workpiece. Note: if you wish to prevent the gradual cutting away of the fence tips (which were designed for this purpose) attach a small wooden fence tip using the screw holes provided.

Panel Saw

This position gives a maximum width capacity of approximately 1000mm, depending on saw size.

Position the fence as shown in Fig. 12, ensuring it is pushed fully toward the outer edge of the table before tightening the clamps, for absolute squareness.

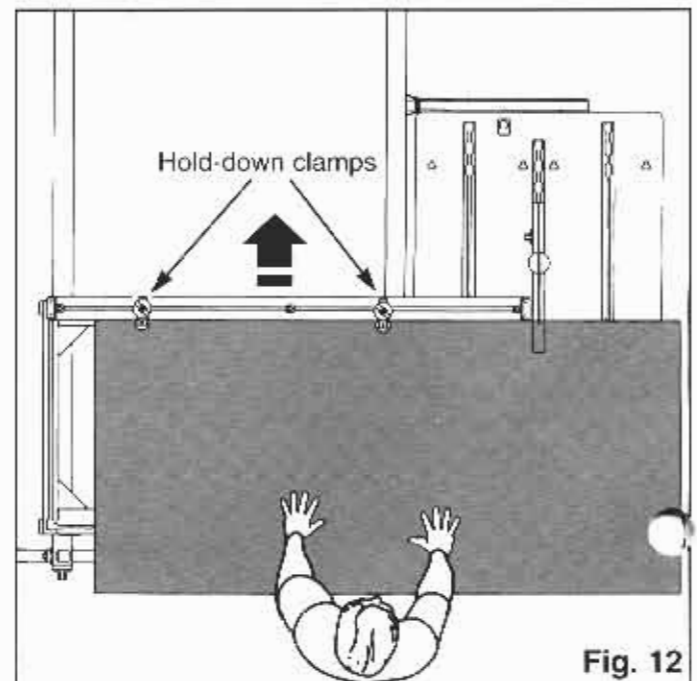

Mitre Cutting

Mitres can be cut with the fence set at a trailing angle (Fig. 13) or leading angle (Fig. 14) and with the workpiece in front (Fig. 13) or behind the fence (Fig. 14)

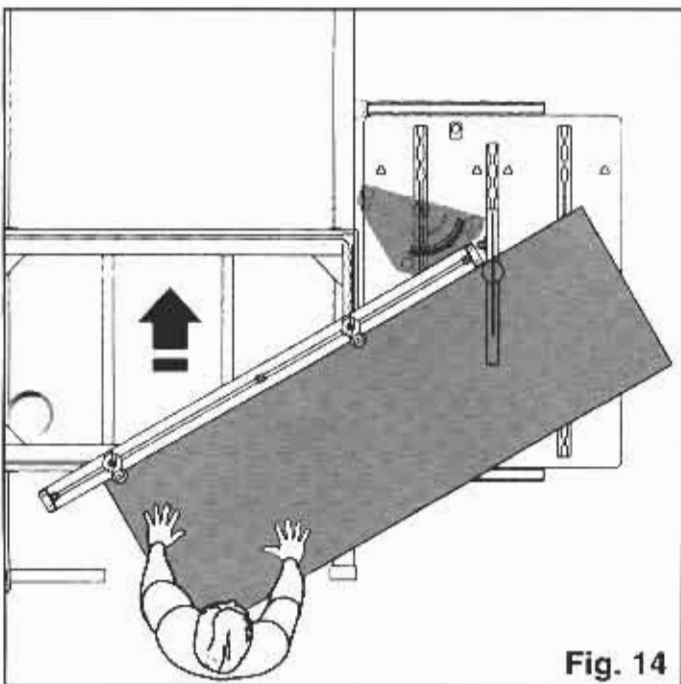
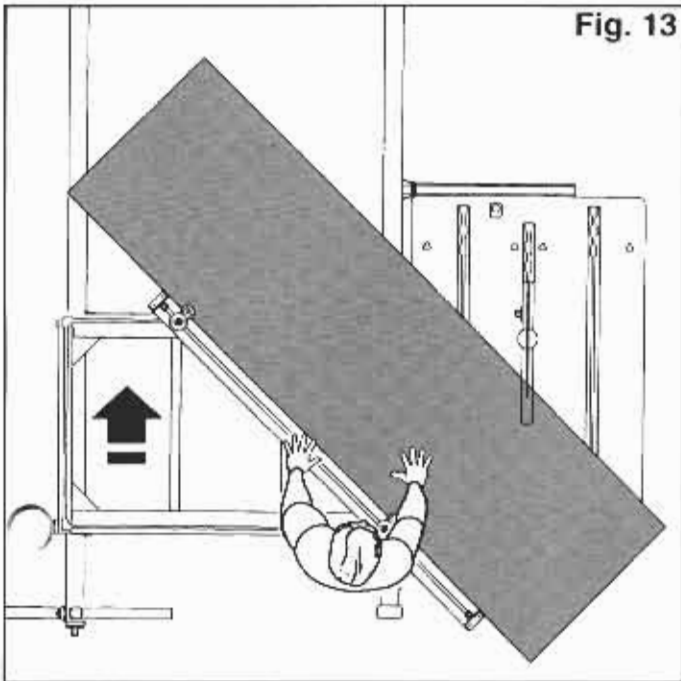

You can use the Workcentre protractor to set the desired mitre angle. Place it in the protractor slot as shown in Fig. 14. Align the extension table fence to the protractor in the position which best suits your workpiece, then remove the protractor.

Taper Ripping

For slight tapers on large workpieces (ie. doors), set the extension table fence to Panel Saw mode and insert a packer against it as shown in Fig. 15.

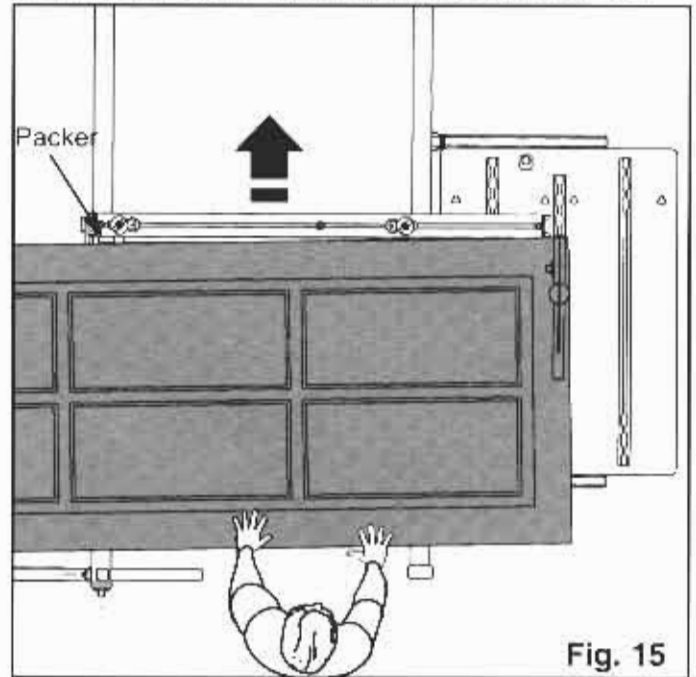

Tapers can also be cut by angling the rip fence. (Fig. 16) The required angle can be achieved by using the Workcentre protractor as outlined in Mitre Cutting. A parallel sided packer will be required to offset the distance between the fence and the protractor in establishing the correct taper angle.

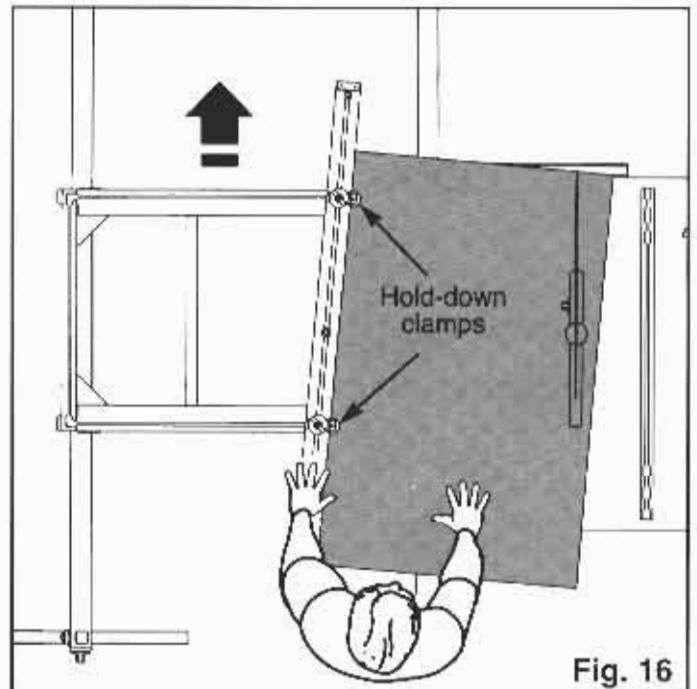

If the fence hold-down clamps do not adequately secure your work when taper ripping, use additional means of clamping the work to the sliding table.

USE WITH THE ROUTER / JIGSAW TABLE

Trenching, edge planing and shaping can be performed in all modes of operation with a Triton Router/Jigsaw Table in place.

Edge Planing

For edge planing pieces up to 1200mm wide, any length, use the Fixed Table position (Fig. 17). Set the extension table fence to the desired width by measuring the distance from the router cutter to the fence, or by performing a test cut.

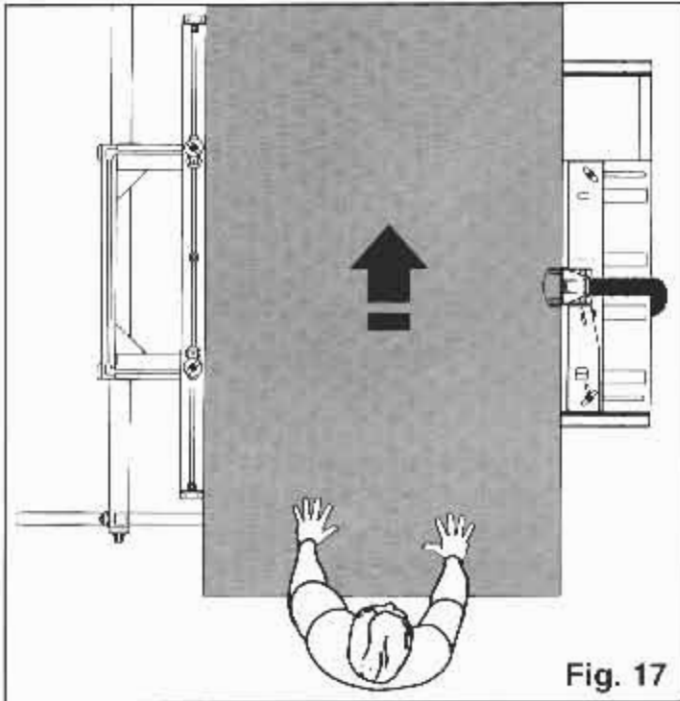

Fig. 17

Set the **rear** section of the router table fence flush with the router cutter and set the front sub-fence to the maximum depth of cut. Guide your work along the extension table fence, not the router table fence.

For planing edges up to 1 metre long you can use the sliding table mode with the extension table fence perpendicular to the router table fence. The router fence should be set just clear of the workpiece, front and rear, and the extension table fence should be used for aligning the workpiece.

Trenching

Trenching is possible in all modes of operation. However, in most instances, it will not be possible to fit the Router / Jigsaw fence and guard. See Fig. 18.

Always use extreme care if using the Router Table without the guard.

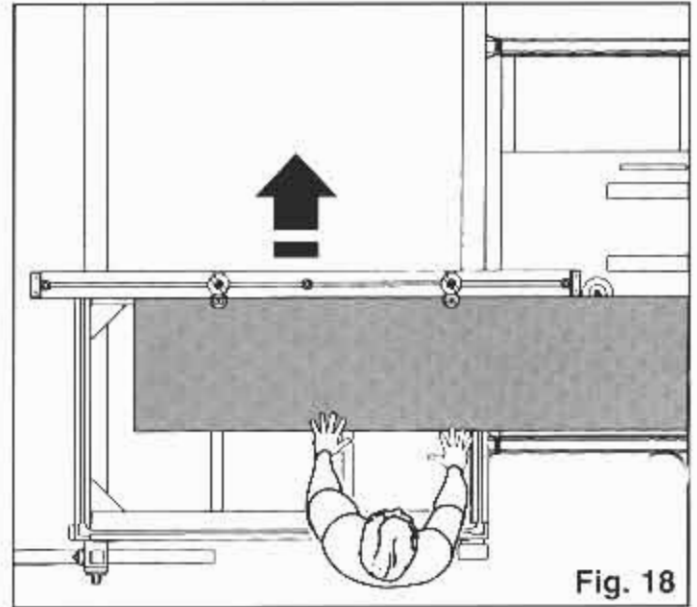

Fig. 18

For large, awkward objects (eg. heavy staircase stringers) it may be best to use the router handheld against a guide clamped to the workpiece.

Made in Australia by: Triton Manufacturing & Design Co. Pty. Ltd. ACN 006 021683

14-18 Mills St, Cheltenham, Vic. 3192 Ph: (03) 9584 6977 Fax: (03) 9584 5510

E-mail: tools@triton.net.au Web Site: <http://triton.net.au>

International Offices:

Canada - Free Call: 1 888 874 8661

Japan - Ph: (08263) 8 0834

New Zealand - Ph: (09) 415 2545

South Africa - Ph: (021) 914 2766

United Kingdom - Free Call: 0800 856 7600